



Atlantic First Nations Water Authority Operators Workshop

SCADA Workshop & Master Plan Updates



AGENDA

- What is SCADA
 - Definitions and Purpose
 - History, Today, Future
- Operator Feedback
- SCADA Master Plan
 - Introduction
 - Scope, Purpose, Objectives
 - Progress to Date
 - Next Steps
- Questions



What is SCADA

Supervisory Control and Data Acquisition

- Ability to monitor from a centralized or remote location
- Is the interface for overseeing and command of a real time process

What is SCADA

Supervisory Control and **Data Acquisition**

- Collection and storage of the real-time process parameters and field instrumentation readings
- Access to collected data on an on-demand basis from a variety of connected or interconnected systems

What do SCADA systems do and why do we need them?

- Provide a graphical interface
- Allow operational changes and control
- Automation of processes
- Continuous monitoring
- Collect and store data
- Annunciate alarms and events
- Ensure staff and public safety
- Troubleshoot problems

History

- Indicator lights
- Push buttons and selector switches
- Gauges
- Knobs for control adjustments
- Simplified process depiction

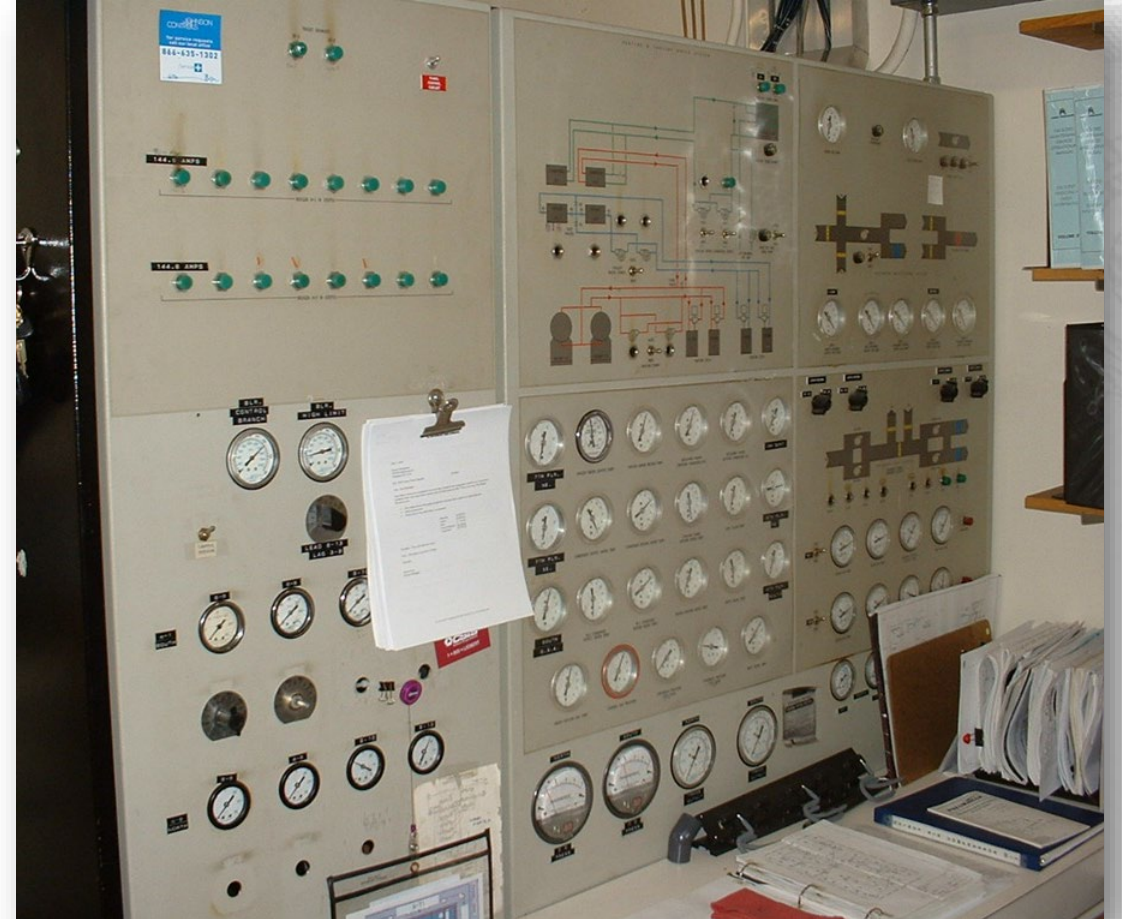

Today

- Computer based graphical user interface
- Mix of hardwired and networked systems
- Automation systems
- Communication systems
- Data storage
- Remote and mobile access

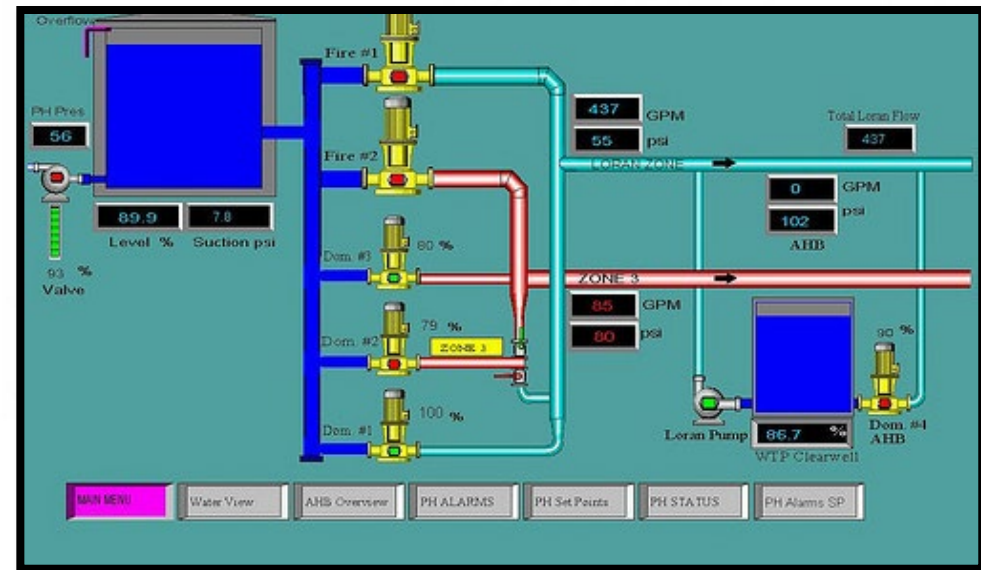
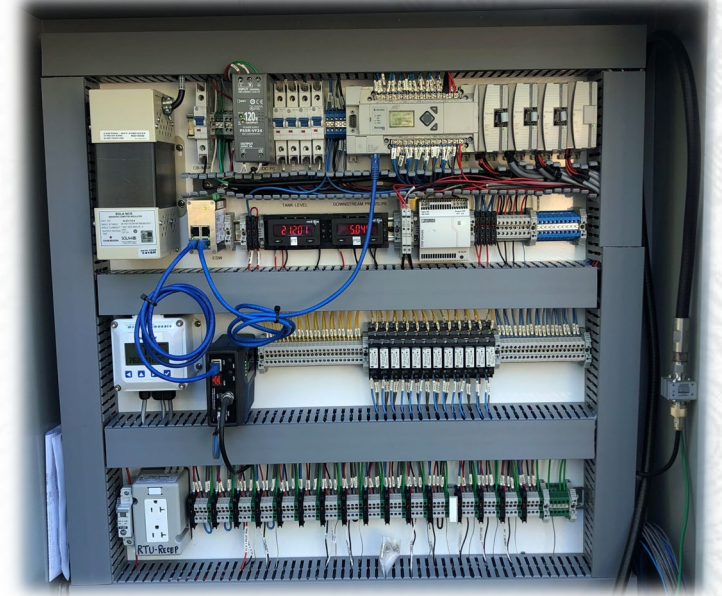

Future Technology Trends

- Virtual technology
- Cloud based systems
- Internet of Things (Industrial)
- Artificial intelligence
- Machine learning
- High Performance HMI
- Interoperability

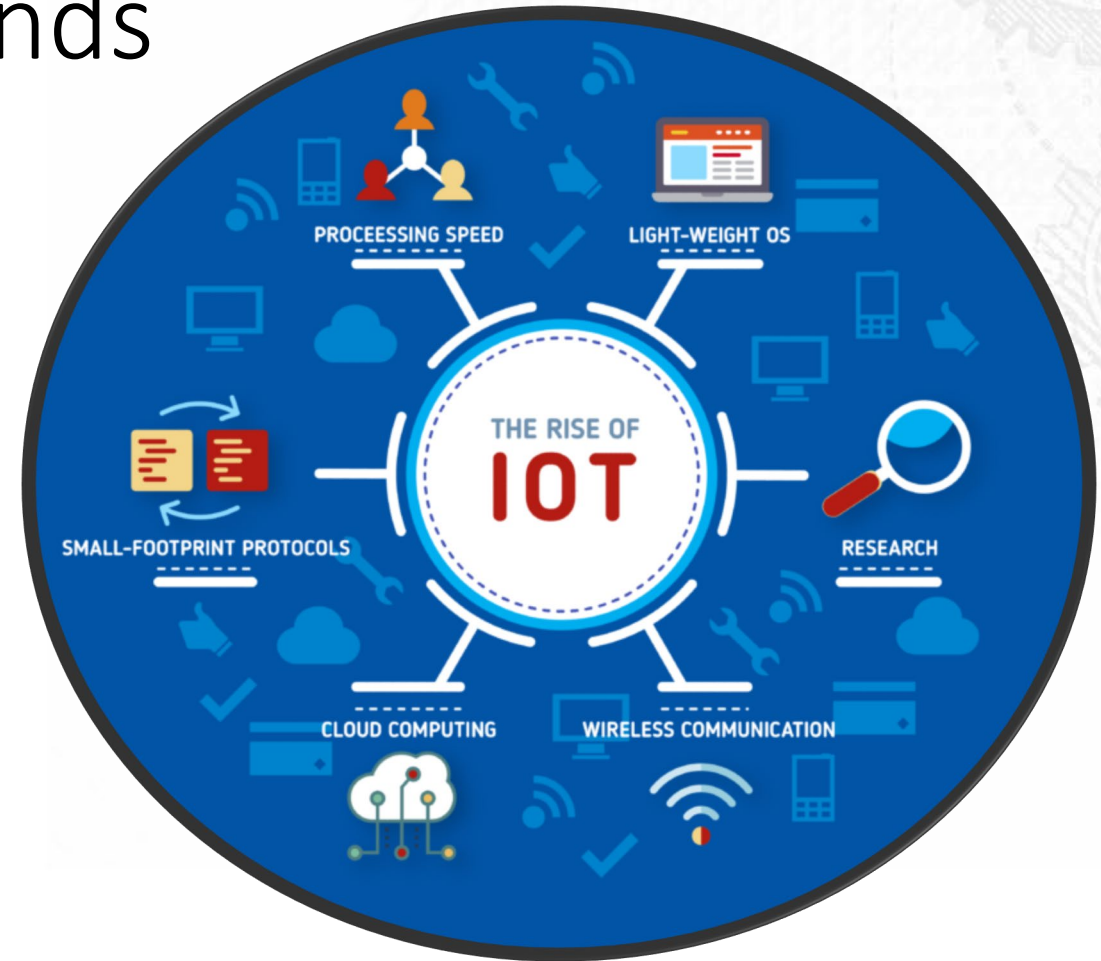



Tell us what you think about SCADA

www.menti.com

Access Code: 7812 7472



SCADA, Process Control & Communications Master Plan – Introduction & Purpose

- AFNWA incorporated July 18, 2018 to own, operate, and maintain water and wastewater systems in participating communities to enhance service and build capacity within First Nation communities.
- Indigenous Services Canada (ISC) has announced funding for asset management type initiatives
- Intent of SMP project is to develop plans for the 5-year implementation of an integrated SCADA system

Full Service - Decentralized

- Reflects Hub & Spoke model
- Tiered SCADA systems
 - Shared visibility to communities within a Regional Operations Hub
 - Centralized monitoring of all systems
- Increased operational coverage



Scope

- Detailed Master Plan with costing for a fully coordinated and integrated system over 5 years.
- Recommendations for:
 - Technology
 - Resources
 - Training
 - Disaster Recovery
 - Cybersecurity

Objectives

- Develop communication framework
- Review current cybersecurity practices & develop plans
- Optimize for reliability and security
- Assess SCADA needs
- Recommend remote terminal unit (RTU) standards and transition plans
- Improve historian use and alarming systems

Progress to Date

December 2020 – March 2021

- Current State

- Site visits & virtual meetings
- Understanding facilities and processes
- Assessment of maturity of existing systems
- Identification of products in use
- Preliminary recommendations for individual communities/facilities/systems
- Focus on product obsolescence, level of available support and alignment with industry best practices and standards
- Understanding of what works well, what doesn't and why
- Allows AFNWA to understand where each community is with SCADA today

Current State Summary

- Little or no documentation
- Mix of hardware platforms
- Wide range of software versions in use
- Several operating systems no longer supported
- Minimal security measures in place
- Majority of lift stations not integrated with SCADA

Component	Level 0	Level I	Level II	Level III	Level IV
Community A		W/WW			
Community B	W/WW				
Community C	WW	W			
Community D	W/WW				
Community E	WW		W		
Community F	WW	W			
Community G	W/WW				
Community H			W/WW		
Community I		W/WW			
Community J		W/WW			
Community K	W/WW				
Community L	W/WW				
Community M	WW	W			
Community N		W/WW			
Community O	WW	W			
Community P	WW	W			

Next Steps

April – August 2021

- Desired State
 - Options for future of SCADA systems for entire AFNWA
 - Focus on needs of Regional Operations Hubs
 - Hardware, software and communications recommendations
 - Evaluation of existing product install base and whether there are opportunities to expand or if migration to other platforms is preferred
 - Consideration of investments to date

Next Steps

April – August 2021

- Desired State
 - Focus on cybersecurity
 - Additional workshops to develop desired state recommendations
 - Recommendations
 - Technical Memoranda
 - Master Plan – implementation roadmap and expenditure plans

